

STORMWATER MANAGEMENT DESIGN ASSISTANCE MANUAL

**For Minor Regulated Activities in
Franklin Township
York County, Pennsylvania**



Simplified Approach

TABLE OF CONTENTS

Introduction	3
Importance of Stormwater Management	3
Standard Terms Used in the Manual	3 - 4
Determining What Type of Stormwater Management Plan is Needed	4
Using Municipal Stormwater Management Worksheets	5
Site Sketch Plan Requirements	5 - 6
Minor Plan Requirements	6 - 7
Disconnected Impervious Area (DIA)	7 - 9
Selecting BMPs	10
Municipal Stormwater Management Worksheets	11 - 18
Stormwater Management/ BMP Facilities & Maintenance Agreement	19 - 23
Samples: Site Sketch Plan, Stormwater Management BMPs	24 - 29
Guide to Choosing Stormwater BMPs	30

Introduction

This design manual has been created as a tool to help property owners manage stormwater on their property and streamline the process of designing on-site stormwater management facilities for new, relatively minor residential and accessory structure projects. Through the use of this manual, residents have the ability to determine the appropriate facilities for their property, project, and budget. This design method is not intended to be used with large-scale subdivision/ land development or activities that include infrastructure such as roadways.

The best management practices (BMPs) listed in this manual should be used as a guide and are not a comprehensive list of options. Residents should contact the municipality or Conservation District to discuss alternative solutions for site specific applications.

Importance of Stormwater Management

Stormwater is the runoff produced by precipitation, snow melt, or ice melt. When land is developed or changed, the flow patterns of water and quality of water are also changed. Land development activities can affect characteristics of stormwater runoff, including the rate of runoff, volume of runoff, and quality of runoff. When runoff is not managed, the increased volume may aggravate flooding and cause pollution downstream.

The objective of stormwater management is to prevent or mitigate the adverse impacts of the increase in rate and volume of stormwater runoff, while also protecting health, safety, and property. Stormwater Best Management Practices aim to maintain water quality, encourage infiltration in appropriate areas, promote groundwater recharge, maintain the natural drainage characteristics of the site to the maximum extent practicable, and protect stream banks and beds.

Standard Terms Used in the Manual

Best Management Practice (BMP) - Activities, facilities, designs, measures, or procedures used to manage stormwater impacts from regulated activities, to meet state water quality requirements, to promote groundwater recharge, and to otherwise meet the purposes of the Ordinance.

Disconnected Impervious Area (DIA) - An impervious or impermeable surface that is disconnected from any stormwater drainage or conveyance system and is redirected or directed to a pervious area, which allows for infiltration, filtration, and increased time of concentration.

Disturbed Area - An unstabilized land area where an earth disturbance activity is occurring or has occurred.

Flow Path – The path that stormwater flows from the discharge point to the nearest property line or channelized flow (i.e., stream, drainage ditch, etc.). The length of the path is measured along the ground slope.

Impervious Surface (Impervious Area) - A surface that prevents the infiltration of water into the ground. Impervious surfaces and areas include but are not limited to roofs, additional indoor living spaces, patios and decks, garages, storage sheds and similar structures, streets, driveways, access drives, parking areas, and sidewalks. Any areas designed to be covered by loose surfacing materials such as gravel, stone and/or crushed stone, and intended for storage of and/or travel by vehicles, or pedestrians shall be considered impervious. Surfaces or areas designed, constructed, and maintained to permit infiltration may be considered pervious.

Karst - A type of topography or landscape characterized by surface depressions, sinkholes, rock pinnacles/uneven bedrock surface, underground drainage, and caves. Karst is formed on carbonate rocks, such as limestone or dolomite.

Minor Stormwater Site Plan – A site plan prepared and submitted to the municipality for proposed projects which qualify to use the Simplified Approach. The plan depicts existing conditions on the property, proposed impervious areas, and, if required, the location of proposed BMPs.

Regulated Activity(ies) - Any earth disturbing activity or any activity that involves the alteration or development of land in a manner that may affect stormwater runoff.

Runoff - Any part of precipitation that flows over the land.

Determining What Type of Stormwater Management Plan is Needed

The chart on the following page provides a guide to determine what type of stormwater plan is needed. Some projects will be exempt from preparing a stormwater management plan, but documentation of the project must still be filed with the municipality. Completion of the **Municipal Stormwater Management Worksheets** will determine what type of documentation is required for each project.

This manual is designed to assist those with projects that qualify for the use of a minor stormwater site plan. If a formal stormwater management plan is required, **a qualified professional must be contacted (ex. Engineer, Surveyor)!**

SWM Plan Requirement	Impervious Area ¹	Disturbed Area ²	Next Steps
<u>LEVEL 1</u> Exempt	Up to 1,000 ft ²	Less than 1 acre	Submit Worksheet A and Site Sketch Plan
<u>LEVEL 2</u> Disconnected Area Exemption	1,000 to ≤ 10,000 ft ² , if 100% disconnected from impervious areas	Less than 1 acre	Submit Worksheets A&B and Site Sketch Plan
<u>LEVEL 3</u> Minor Stormwater	1,000 ft ² to ≤ 5,000 ft ² IF connected to	Less than 1 acre	Submit Minor Stormwater Site Plan, Including Worksheets A&B, BMPs,

Site Plan	impervious areas		and O&M Agreement
<u>LEVEL 4</u> Formal Stormwater Management Plan	Greater than 5,000 ft ² of impervious area if Level 2 and Level 3 criteria are not met	Less than 1 acre	Consult a Qualified Professional

¹*New Impervious area must be cumulatively calculated, starting at the date of adoption of the Franklin Township Stormwater Management Ordinance.*

²*The above table is only applicable to projects with disturbed areas of less than one (1) acre. Any projects that propose more than one (1) acre of disturbed area are subject to NPDES Permit requirements and will require a Formal Stormwater Management Plan.*

Using Municipal Stormwater Management Worksheets

Determining the impervious area of a proposed project is the first step in using this Manual. Municipal Stormwater Management Worksheets have been included in the Simplified Approach, which will assist the property owner, or applicant, and municipality determine the impervious area of a proposed project and provide guidance through the next steps.

Municipal Stormwater Management Worksheet A – Step 1: If the total proposed surface area is up to 1,000 square feet, the project may be exempt from the requirements in this guide as a Level 1 project. The owner shall provide a Site Sketch Plan and must sign the Acknowledgement at the top of the sheet and file it with the municipality for approval. If determined to be exempt by the municipality, the worksheet will be considered complete.

****If the proposed impervious area is greater than 1,000 square feet, proceed to Worksheet B – Step 2.****

Municipal Stormwater Management Worksheet B – Steps 2 through 4: If the proposed impervious area is between 1,000 square feet and 10,000 square feet, the applicant must determine the Disconnected Impervious Area (DIA).

Level 2 Project – If the proposed impervious area is between 1,000 square feet and 10,000 square feet and is determined to be entirely disconnected in accordance with the Disconnected Impervious Area criteria, the project may be exempt from the requirements of this guide. The owner must provide a Site Sketch Plan and Worksheets A and B to the municipality for approval. If the project is determined to meet the Level 2 exemption criteria, the application will be considered complete.

Level 3 Project – If the proposed project proposes between 1,000 square feet and 5,000 square feet of impervious area that does not meet the Disconnected Impervious Area criteria, a Minor Stormwater Site Plan is required. This plan must include fully completed Worksheets A&B, a Site Sketch Plan showing the location of any proposed stormwater BMPs, and the O&M Agreement for the proposed BMPs. Stormwater Management BMPs may be selected from the sample BMPs provided within this document or within the Guide to Choosing Stormwater BMPs. The Minor Stormwater Site Plan must then be submitted to the municipality for review and approval.

Level 4 Project – If the proposed project proposes greater than 5,000 square feet of impervious area that does not meet the Disconnected Impervious Area criteria or greater than 10,000 square feet of Disconnected Impervious Area, the project does not meet the criteria of a Minor Stormwater Site Plan. A Qualified Professional must be contacted to prepare a stormwater management plan in accordance with the Municipal Stormwater Management Ordinance.

Site Sketch Plan Requirements – Level 1 and Level 2

A Site Sketch Plan depicting the key features of the site must be drawn, or depicted, to scale to show the following:

Level 1 Site Sketch Plan Requirements:

- 1) Property boundary, address, and name of landowner.
- 2) Location of all existing and proposed structures (house, shed, addition, etc.) and any proposed downspouts. Include the dimensions of proposed structures and distance to property lines.
- 3) Site conditions and land covers (grassed areas, agricultural fields, direction of slope and stormwater flow on the property).

- 4) All existing and proposed driveways and impervious areas, including dimensions of proposed areas (stone and gravel driveways are considered impervious).
- 5) Natural features such as floodplains, streams, wetlands, tree lines and other vegetation on the property and within 50 feet of the property line for lots smaller than 5 acres.
- 6) Utility lines, sewer or water service location, or wells and on-site septic systems.

Additional Level 2 Site Sketch Plan Requirements (Including all Level 1 requirements):

- 7) Distance from proposed downspouts to property line.
- 8) Approximate slopes of overland stormwater flow paths
- 9) Distance from proposed structures or downspouts along the stormwater flow path to any stream or wooded area.
- 10) Any other pertinent information that may be significant to the project site (existing drainage ways, steep slopes, etc.).
- 11) Soil boundaries and types for the project area [may be obtained from PA Soil Map (soilmap.psu.edu) or NRCS Web Soil Survey (websoilsurvey.nrcs.usda.gov)].

Level 3 - Minor Stormwater Site Plan Requirements

A minor stormwater site plan depicts the existing conditions of a property and the location of proposed impervious surfaces. Depicting the relationship between the proposed activities and distances to things like property lines, streams, and vegetated areas will help determine if the stormwater runoff created by the proposed project can be managed naturally within the property or if additional best management practices (BMPs) are needed to accommodate the stormwater runoff.

If a project qualifies for use of a minor stormwater site plan, the applicant may prepare and submit to the Municipality a minor stormwater site plan and the applicable Municipal Stormwater Management Worksheets. The York County GIS Office can also provide assistance to applicants to obtain property maps of existing features. A Site Sketch Plan depicting the key features of the site must be drawn, or depicted, to scale to show the information required for a Level 1 and Level 2 Site Sketch Plan and the following additional information when BMPs are required:

- 12) Any proposed tree or shrub plantings and species
- 13) Location, size, and depth of proposed stormwater BMPs.
- 14) Details of proposed stormwater BMPs, including materials to be used.

Other Considerations for Minor Plans:

While soil testing is not mandatory for the simplified approach, soil testing is highly recommended to select and apply the appropriate stormwater BMPs. The use of soil maps, infiltration tests, and/or percolation tests may provide the applicant basic information about soil characteristics.

- Proposed stormwater management facilities must be designed to handle flows from the contributing area.
- The site shall not have any pre-existing stormwater drainage-related problems (as verified by the municipality).
- Water quality shall be protected per Chapter 93 of PA Code (<http://www.pacode.com/>).
- The municipality may inspect all BMPs during and after construction/installation.
- Infiltration BMPs should not be constructed nor receive runoff until the entire contributory drainage area has achieved final stabilization.
- Ensure that infiltration in geologically susceptible areas such as, but not limited to, carbonate geology/ karst topography does not cause adverse effects. The minor stormwater site plan

- should incorporate steps to ensure that salt or chloride will not contaminate the groundwater.
- Selected BMPs shall be designed, constructed, and maintained in accordance with the manufacturer's recommendation, the BMP Manual, or other written guidance acceptable to the municipality.
- Proposed sump pumps shall discharge to infiltration or vegetative BMPs to the maximum extent practicable.

DISCONNECTED IMPERVIOUS AREA (DIA)

When impervious surface areas like rooftops and paved areas are directed to a pervious area that allows for infiltration, filtration, and increased time of concentration, the impervious surface areas may qualify to be treated as Disconnected Impervious Area (DIAs).

Impervious Area is defined as: A surface that prevents the infiltration of water into the ground. Impervious surfaces and areas shall include roofs, home additions, patios and decks, garages, storage sheds and similar structures, driveways, access drives, parking areas, walkways, and sidewalks. Any areas designed to be covered by loose surfacing materials such as gravel, stone and/or crushed stone, and intended for storage of and/or travel by vehicles, or pedestrians shall be considered impervious.

Surfaces or areas designed, constructed, and maintained to permit infiltration may be considered pervious.

Rooftop Disconnection: A rooftop is considered to be completely disconnected if it meets the requirements listed below:

- The contributing area of rooftop to each disconnected discharge (downspout) is 500 square feet or less.
- The overland flow path from roof runoff discharge point has a positive slope of five percent (5%) or less.
- The length of the overland flow path is greater than 75 feet.
- Soils along the overland flow path are not classified as hydrologic group "D" (See Plan Appendix B). i.e., infiltration is at least 1 inch per 24-hour day.
- The receiving pervious area shall not include another person's property unless written permission has been obtained from the affected property owner.

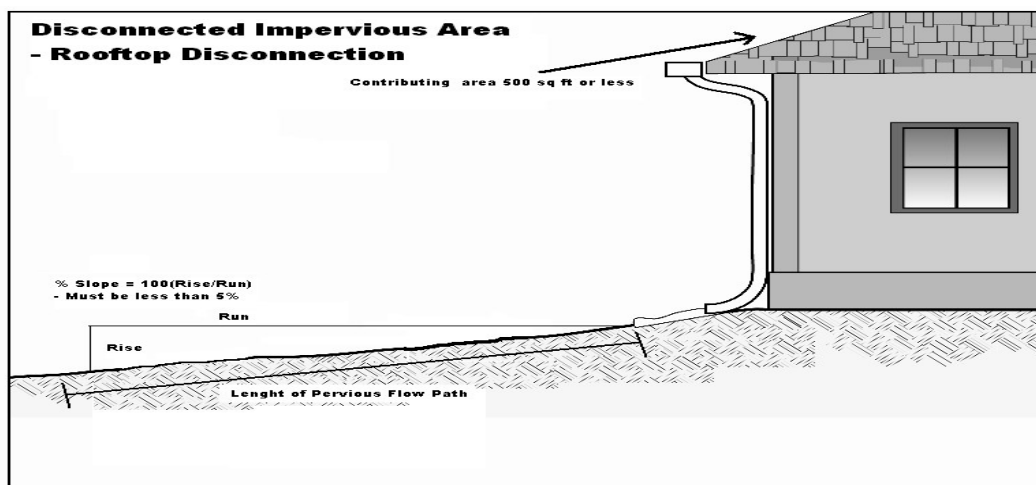

Note: Downspout not required.

Determining Status of DIA

Step 1: Determine contributing area of the roof to each disconnected discharge (downspout). If it is 500 ft² or less, continue to step 2. If it is greater than 500 ft², the area does not qualify as DIA.

Step 2: Determine the length of down slope pervious flow path available for each disconnected discharge.

Step 3: Determine the % slope of the pervious flow path, % slope = (rise/run) x 100. Must be 5% or less.

Step 4: See the table on the next page to determine the percentage of the area that can be treated as disconnected. If the available length of the flow path is equal to or greater than 75 ft, the discharge qualifies as entirely disconnected.

Partial Rooftop Disconnection		
Length of Pervious Flow Path* (ft) Lots 10,000 ft ² and Under	Length of Pervious Flow Path* (ft)	Roof Area Treated as Disconnected
0 – 7.9	0 – 14	0%
8 – 15.9	15 – 29	20%
16 – 22.9	30 – 44	40%
23 – 29.9	45 – 59	60%
30 – 34.9	60 – 74	80%
35 or more	75 or more	100%
*Pervious flow path must be at least 15 feet from any impervious surface and cannot include impervious surfaces.		

Paved Surface Disconnection: When runoff from paved surfaces is directed to a pervious area that allows for infiltration, filtration, and increased time of concentration, the contributing pavement area may qualify as disconnected. This applies generally to only small or narrow pavement structures such as driveways and walkways. Paved surfaces can be considered disconnected if they, or the adjacent areas, meet the following requirements:

- The contributing flow path over the impervious area is not more than 75 feet.
- The length of overland flow is greater than or equal to the maximum length of flow over the impervious area.
- The slope of the contributing impervious area is five percent (5%) or less.
- The slope of the overland flow path is five percent (5%) or less.
- If discharge is concentrated at one or more discrete points, no more than 1,000 ft² may discharge to any one point. In addition, a gravel strip or other spreading device is required for concentrated discharges. For non-concentrated discharges along the entire edge of paved surface, a level spreader is not required; however, there must be

provisions for the establishment of vegetation along the paved edge and temporary stabilization of the area until the vegetation is established.

REFERENCE: Philadelphia Water Department. 2006 & 2011. Stormwater Management Guidance Manual. Section 4: Integrated Site Design. Philadelphia, PA.

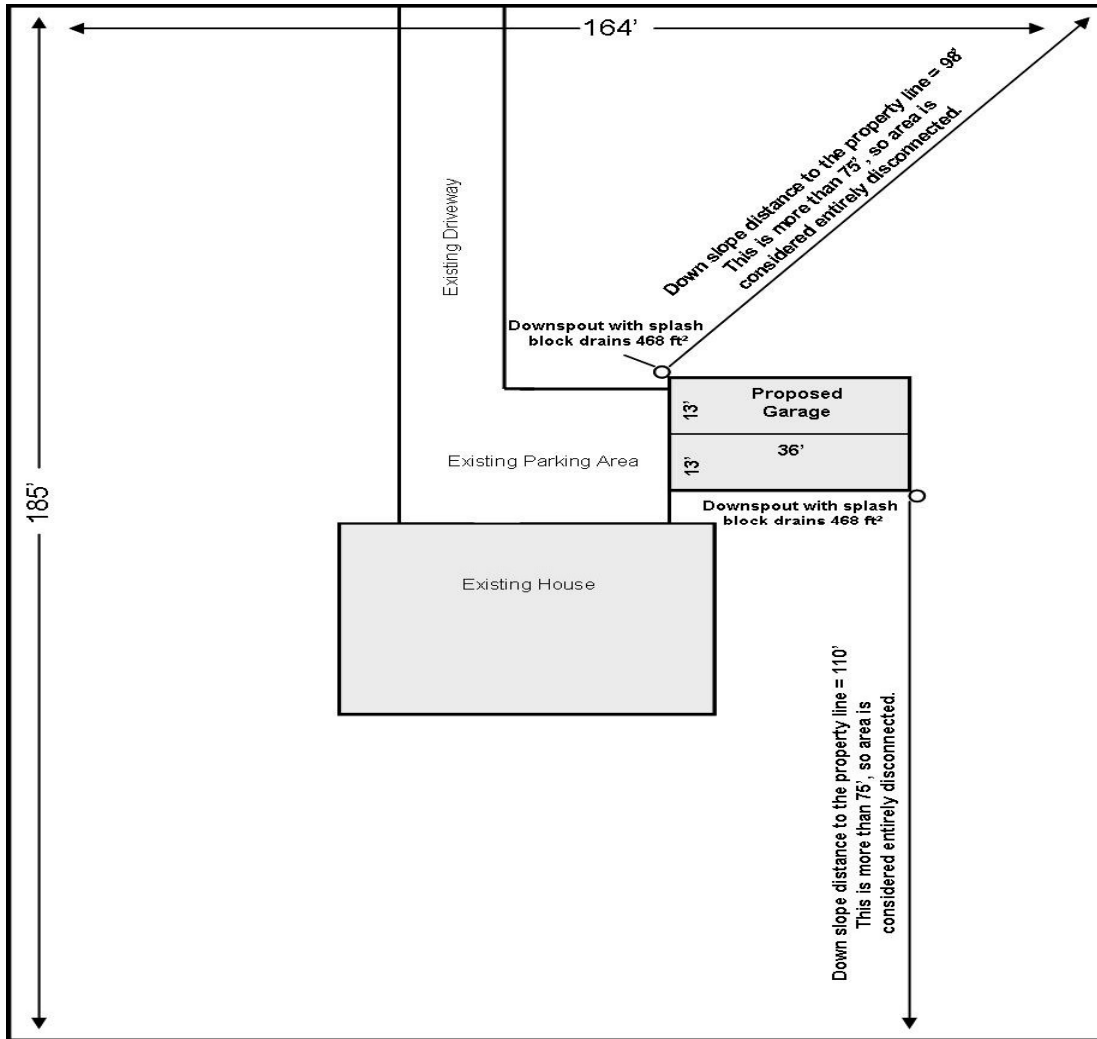

**The following example determines the status of the DIA for a proposed 936 ft² garage.
This example meets the criteria to use the Simplified Approach.**

Step 1: Determine the area to each disconnected discharge. The area draining to each downspout is 468ft². This is less than 500 ft², proceed to step 2.

Step 2: The discharge on the north side of the garage has a 98 ft pervious flow path available. The south discharge has 110 ft pervious flow path available.

Step 3: The rise of the north discharge is 2 ft, and the run is 75 ft for a slope of 2.6%. This is 5% or less so it qualifies. For the south discharge, the rise is 4 ft, and the run is 100 ft equaling a slope of 4%. This is 5% or less, so it qualifies.

Step 4: Both of these discharges have pervious flow paths greater than 75 ft, so they qualify as entirely disconnected.

Selecting BMPs

If BMPs are required, the Owner/ Designer should review the compiled information in the enclosed “Guide to Choosing Stormwater BMPs”, as taken from the *PA Handbook of Best Management Practices for Developing Areas* and the *PA Stormwater Management BMP Manual*. These documents identify stormwater BMPs that have been deemed to be of a nature and cost that will accomplish the goals of the York County Stormwater Management Plan, while not unduly burdening the residents. It will then be the Owner’s responsibility to select a facility, determine the appropriate size and agree to construct and maintain that facility or facilities. The property owner is encouraged to utilize both multiple and hybrid versions of the facilities, as outlined in the documents mentioned above.

Municipal Stormwater Management Worksheets

Municipal Stormwater Management Worksheet A

Property Owner's Name: _____

Address of Property: _____

Parcel ID #: _____ Municipality: _____

Phone Number: _____

New Impervious Area Associated with this Project _____

Stormwater Project Type: ____ Level 1 ____ Level 2 ____ Level 3 ____ Level 4

Exempt

Minor Plan

Formal Plan

Estimated Project Disturbed Area (Square Feet or Acres) _____

Total New Impervious Area Since Adoption of SWM Plan _____

Acknowledgement- I declare that I am the property owner, or representative of the owner, and that the information provided is accurate to the best of my knowledge. I understand that stormwater may not adversely affect adjacent properties or be directed onto another property without written permission. I also understand that false information may result in a stop work order or revocation of permits. Municipal representatives are also granted reasonable access to the property for review and/or inspection of this project if necessary.

Signature _____ Date: _____

Step 1: Determine the amount of new impervious area created by the proposed project. This includes any new surface areas that prevent infiltration of stormwater into the ground. New stone and gravel areas are considered impervious. Impervious areas existing before May 8, 2013, are not included in this calculation. Use additional sheets if necessary.

Calculate new impervious area by completing this table.

Surface	Length (ft)	x	Width (ft)	=	Impervious Area (ft ²)
Buildings		x		=	
Driveway		x		=	
Parking Areas		x		=	
Patios/ walkways		x		=	
Other		x		=	
Total Proposed Impervious Surface Area (Sum of all impervious areas)					

- Level 1 - If the total new impervious surface area is **up to 1,000 ft²**, the project is exempt from the requirement to submit a plan for approval. Sign Acknowledgement and file this sheet with municipality.
- Level 2 - If total impervious surface area is **1,001 ft² to 10,000 ft²**, continue to Step 2.
 - If project area can be entirely disconnected, sign Acknowledgement and file worksheets with municipality.
- Level 3 - If project is between **1,000 ft² and 5,000 ft²** and requires BMPs, complete step 3.
- Level 4 – If project area is **greater than 5,000 ft²** and cannot be disconnected, the project does not qualify for the Simplified Approach.

Municipal Stormwater Management Worksheet B

Step 2: Determine Disconnected Impervious Area (DIA). All or parts of proposed impervious surfaces may qualify as Disconnected Impervious Area if runoff is directed to a pervious area that allows for infiltration, filtration, and increased time of concentration. The volume of stormwater that needs to be managed could be reduced through DIA. Prepare a minor stormwater site plan (see page 6 for requirements).

Criteria

- Overland flow path from the discharge area or impervious area has a positive slope of 5% or less.
- Contributing area to each rooftop discharge (downspout) is 500 ft² or less.
- Soils are not classified as hydrologic soil group "D".
- The receiving pervious area shall not include another person's property unless written permission has been obtained from the affected property owner.

Paved Disconnection Criteria: Paved surfaces (driveways, walkways, etc.) and gravel can be considered disconnected if it meets the criteria above and:

- Runoff does not flow over impervious area for more than 75 feet.
- The length of overland flow is greater than or equal to the contributing flow path.
- The slope of the contributing impervious areas is 5% or less.
- If discharge is concentrated at one or more discrete points, no more than 1,000 ft² may discharge to any one point. In addition, a gravel strip or other spreading device is required for concentrated discharges. Non-concentrated discharges along the entire edge of paved surface must include provisions for the establishment of vegetation along the paved edge and temporary stabilization of the area until the vegetation is established.
- If these criteria can be met, the DIA credit = 0

Partial Rooftop Disconnection		
Length of Pervious Flow Path (ft) Lots ≤ 10,000 ft ²	Length of Pervious Flow Path (ft)	DIA Credit Factor
35 or more	75 or more	0
30 – 34.9	60 – 74	0.2
23 – 29.9	45 – 59	0.4
16 – 22.9	30 – 44	0.6
8 – 15.9	15 – 29	0.8
0 – 7.9	0 - 14	1.0
Pervious flow path must be at least 15 feet from any impervious surface		

Using the calculations from Step 1, complete the table below. This will determine the impervious area that may be excluded from the area that needs to be managed through stormwater BMPs. If the total impervious area to be managed = 0, the area can be considered entirely disconnected.

Surface	Proposed Impervious Area	x	DIA Credit	=	Impervious Area (ft ²) to be Managed
Buildings (area to each downspout)		X		=	
Driveway		X		=	
Parking Areas		X		=	
Patios/ walkways		X		=	
Other		X		=	
Total Proposed Impervious Surface Area to be managed (Sum of all impervious areas)					

*** If Total Proposed Impervious Surface Area to be managed is greater than 0, continue to Step 3.**

**** If Total Proposed Impervious Surface Area to be managed is greater than 5,000 sf., a Formal Stormwater Management Plan is required, and a Qualified Professional must be contacted.**

Municipal Stormwater Management Worksheet B

Step 3: Calculate the volume of stormwater runoff created by proposed impervious surfaces or see Simple BMP Sizing in Step 4.

Impervious Area (ft ²) to be Managed (Sum of Step 2)	X	3.0 in/12 in = 0.25 (3.0 in is 2-year 24-hour rainfall amount)	=	Amount of Stormwater to be Managed (ft ³)
	X	0.25	=	

Step 4: Select BMPs and size according to the volume of stormwater that needs to be managed. The Guide to Choosing Stormwater BMPs, included in the Simplified Approach, includes sizing calculations for specific techniques. The table below should be used only when a Minor Stormwater Site Plan is appropriate. Other BMPs may be utilized if selected out of the Guide to Choosing Stormwater BMPs provided calculations are provided to show that the required volume has been met.

Best Management Practices need to be used to manage the volume of stormwater created by the proposed impervious areas. The cubic feet of stormwater that need to be managed may also be further reduced by planting new trees. If the criteria below can be met, the amount of stormwater to be managed can be reduced per the following:

Deciduous Trees = 6 ft³ per tree

Evergreen Trees = 10 ft³ per tree

Criteria:

- Trees must be PA native species (See PA Stormwater BMP Manual for a list).
- Trees shall be a minimum of 1" caliper tree and 3 feet tall shrub (min).
- Trees shall be adequately protected during construction.
- No more than 25% of the required capture volume can be mitigated through the use of trees.
- Dead trees shall be replaced by the property owner within 12 months.
- Please consider the specifications for each tree species when determining location and spacing.

Amount of Stormwater to be Managed (ft ³) (Sum of Step 3)	-	Tree Planting Credit (ft ³)	=	Amount of Stormwater to be Managed (ft ³)
	-		=	

Proposed BMP	Length (Feet)	Width (Feet)	Depth (Feet)	Void Ratio	Volume (Cubic Feet)
Infiltration Bed	x	x	x	0.4	=
Infiltration Berm	x	x	x	1.0	=
Rain Garden	x	x	x	1.0	=
Rain Barrel	Gallons		Cubic Feet Per Gallon		=
			x	0.134	
Tree Credit	Calculated Above (Can be up to a maximum of 25% of the required volume calculated in Step 3)				=
Total Volume Credit (Sum of Volumes above)					=
Required Volume (Calculated above in Step 3)					=
Surplus Volume (Total Volume – Required Volume)					=

Bring the worksheets, Site Sketch Plan, Owner Acknowledgement, and Stormwater Management Practices, Facilities, and Systems Maintenance and Monitoring Agreement to the municipality. If an area greater than 5,000 square feet of earth is disturbed, an erosion and sedimentation (E & S) control plan must be prepared and kept on site during construction activities. If an area greater than 1.0 acres is disturbed during the project, an NPDES Permit will be required to be obtained from the York County Conservation District.

OWNER ACKNOWLEDGMENT

- Development activities shall begin only after the municipality approves the plan.
- The installed BMPs are not permitted to adversely affect any property, septic systems, or drinking water wells on this or any other property.
- If a stormwater management alternative to the approved stormwater site plan is used, the applicant will submit a revised plan to the municipality for approval. If a site requires a more complex system or if problems arise, the applicant may need the assistance of a licensed professional.
- The applicant acknowledges that the proposed stormwater management BMPs will be a permanent fixture of the property that cannot be altered or removed without approval by the Township.

I (we), _____, hereby acknowledge the above statements and agree to assume full responsibility for the design, implementation, construction, operation, and maintenance of the proposed stormwater management facilities. Furthermore, I (we) also acknowledge that the steps, assumptions, and guidelines provided in this stormwater site plan & applicable report or worksheet(s) will be adhered to.

Signature: _____

Date: _____

Print : _____

Signature: _____

Date: _____

Print : _____

SAMPLES:

SITE SKETCH PLAN

STORMWATER MANAGEMENT BMPs

EXISTING
 HOUSE=2400 SQ. FT.
 SIDEWALK=50 SQ. FT.
 DRIVEWAY=4000 SQ. FT.

PROPOSED
 GARAGE=750 SQ. FT.
 DRIVEWAY=150 SQ. FT.
 (5'x30' ADDED)

TOTAL EXISTING AND
 PROPOSED=7350 SQ. FT.

NOTE:
 THERE ARE NO STREAMS,
 WETLANDS, OR FLOODPLAINS
 ON THE PROPERTY.

CONTACT INFORMATION:
 PROPERTY OWNER(S)
 ADDRESS
 PHONE NUMBER(S)
 EMAIL ADDRESS

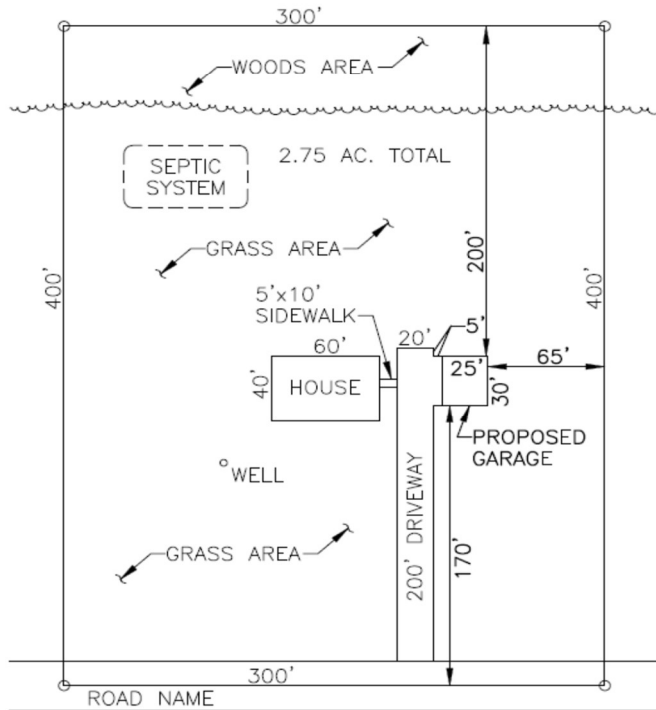

SAMPLE STORMWATER SITE SKETCH PLAN (LEVEL 1)
 SCALE: N.T.S.

GENERAL NOTE:
 PLEASE SEE APPENDIX B FOR COMPLETE LIST OF REQUIRED INFORMATION.

REVISIONS		SAMPLE STORMWATER SITE SKETCH PLAN		SCALE AS SHOWN
DRAWN BY: FSL	DATE: 07/25/12	FRANKLIN TOWNSHIP SAMPLE STORMWATER SITE SKETCH PLAN FRANKLIN TOWNSHIP, YORK COUNTY, PA		SHEET NO. 1 OF 1
DESIGNED BY: EMV	CHECKED BY: WFK			

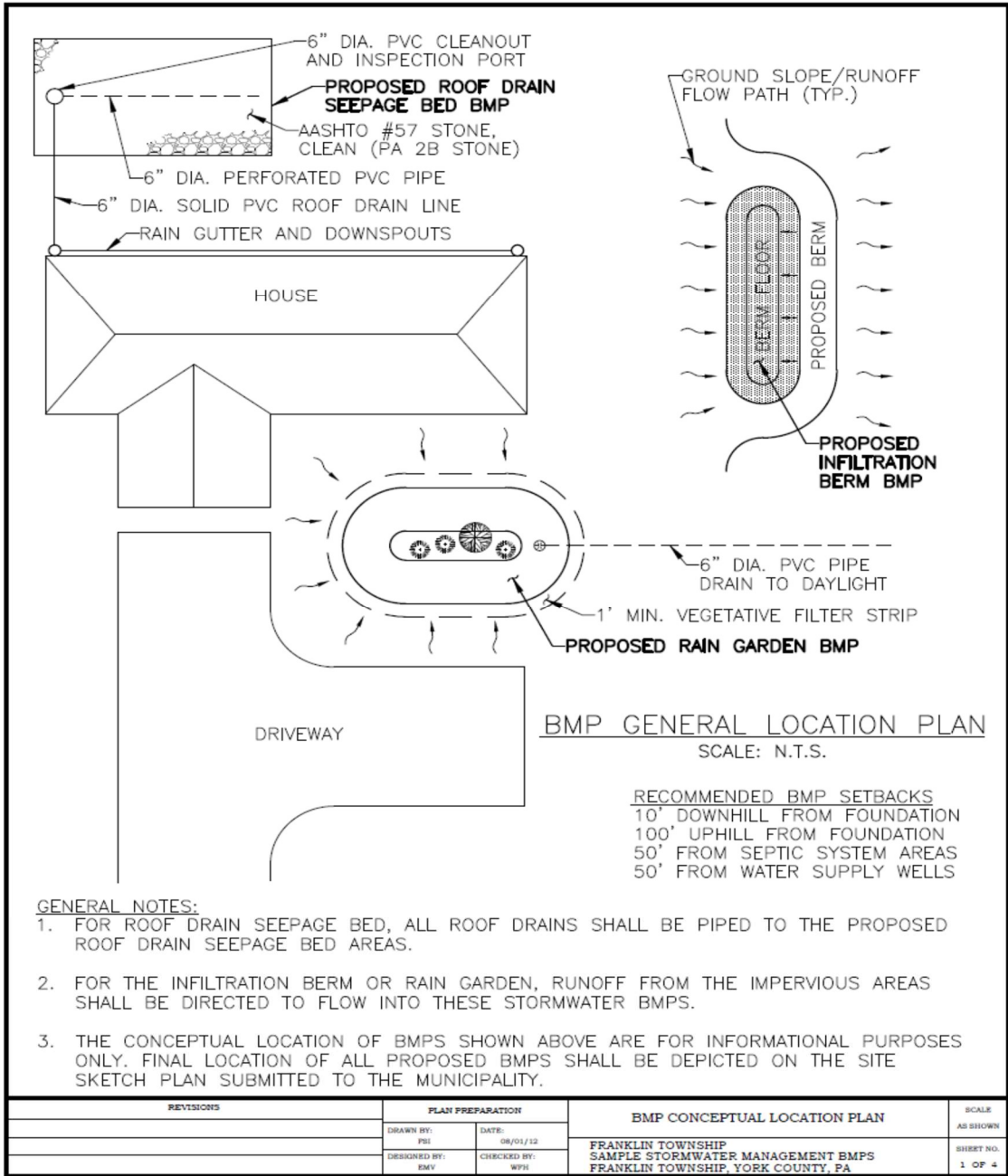

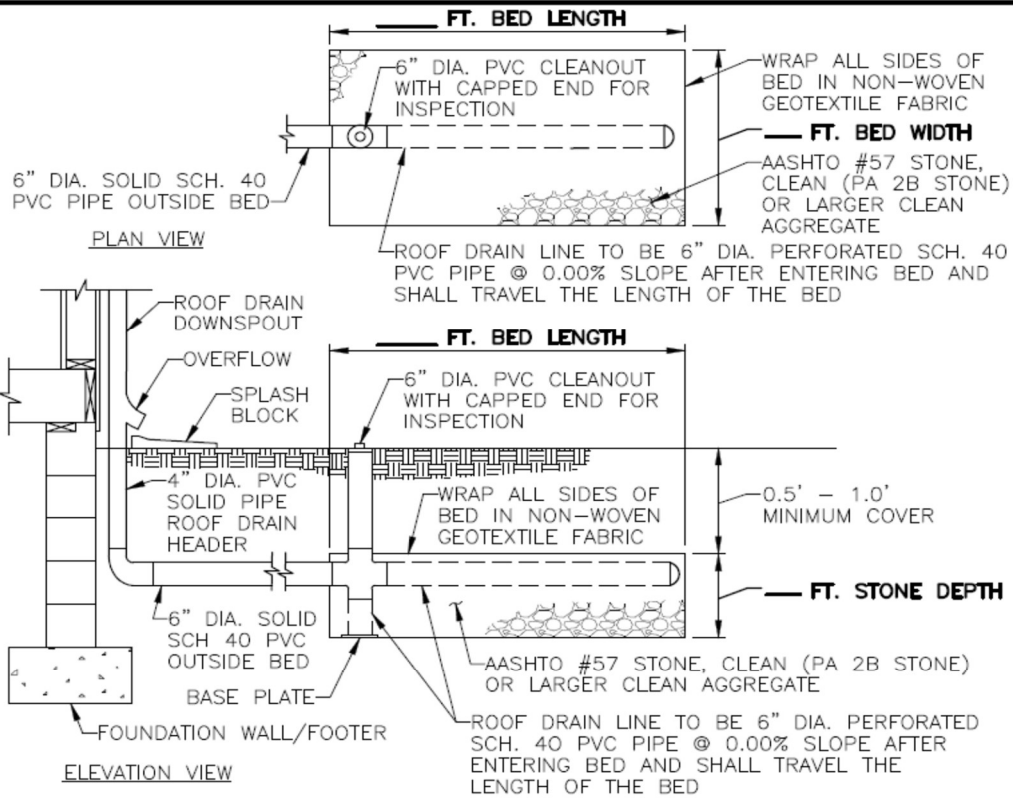

ROOF DRAIN SEEPAGE BED DETAIL

SCALE: N.T.S.

GENERAL NOTES:

1. SEEPAGE BEDS SHALL BE CONSTRUCTED WITH A FLAT BOTTOM.
2. DEPTH OF STONE SHOULD BE 2.5' OR LESS UNLESS SOIL TESTING HAS BEEN PERFORMED.
3. ALL SCHEDULE 40 PVC PIPE SHALL BE ASTM D-1785.
4. ALL ROOF DRAIN LINES SHALL BE SOLID PVC PIPE PRIOR TO ENTERING THE STONE INFILTRATION BED. UPON ENTERING THE BED, ALL PIPE SHALL BE PERFORATED PVC PIPE.
5. PROVIDE LEAF GUARDS ON GUTTERS.
6. ANY MODIFICATIONS TO THE DEPICTED SEEPAGE BED SHALL BE ONLY AS APPROVED BY THE TOWNSHIP OR DESIGNATED REPRESENTATIVE.
7. THE TOWNSHIP ENGINEER SHALL BE CONTACTED PRIOR TO INSTALLATION OF THE SEEPAGE BED TO COORDINATE ANY NECESSARY INSPECTIONS.

REVISIONS	PLAN PREPARATION		BMP - SEEPAGE BED DETAIL	SCALE
	DRAWN BY:	DATE:		AS SHOWN
	PSE	08/01/12	FRANKLIN TOWNSHIP SAMPLE STORMWATER MANAGEMENT BMPS FRANKLIN TOWNSHIP, YORK COUNTY, PA	SHEET NO. 2 OF 4
	DESIGNED BY: RMV	CHECKED BY: WPH		

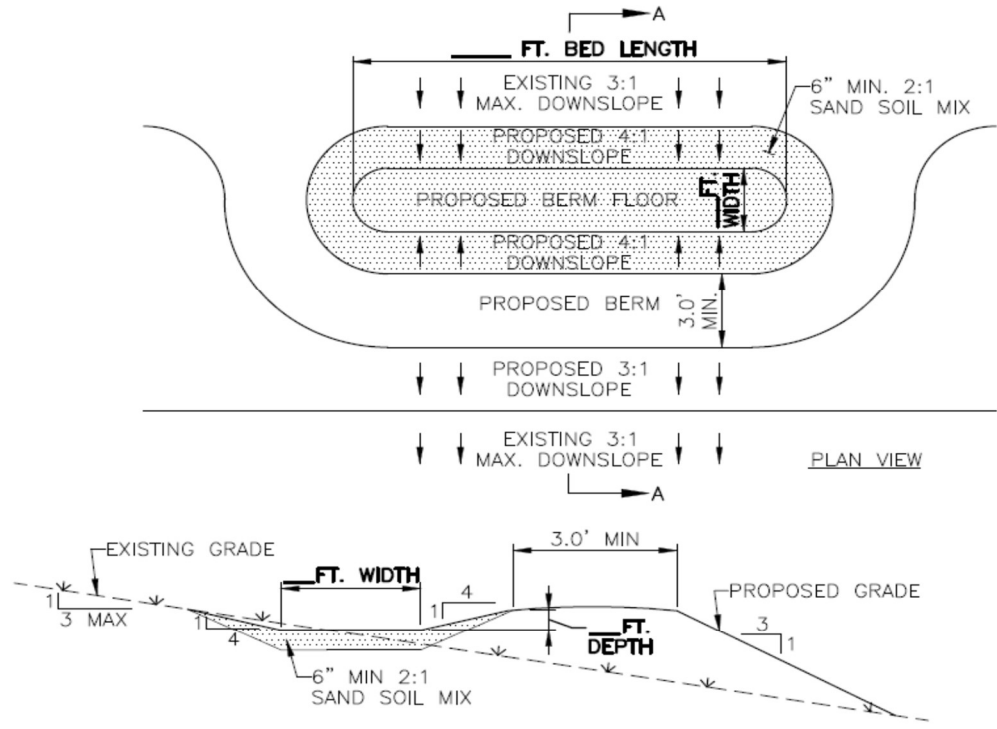

INFILTRATION BERM DETAIL SECTION A-A
SCALE: N.T.S.

GENERAL NOTES:

1. INFILTRATION BERM SHALL BE INSTALLED WITH THE TOP OF THE BERM AT A LEVEL GRADE ALONG THE ENTIRE BED, TO ENSURE AN EVEN OVERFLOW DISTRIBUTION.
2. ENTIRE LENGTH OF INFILTRATION BERM SHALL BE UNDERLAIN WITH SIX (6) INCHES MINIMUM OF A 2:1 SAND SOIL MIXTURE.
3. IF THE LANDOWNER DESIRES, TREES AND/OR SHRUBS CAN BE PLANTED IN THE INTERIOR OF THE INFILTRATION BERM. CARE SHOULD BE TAKEN TO ENSURE THAT ALL TREES OR SHRUBS PLANTED WITHIN THE BERM ARE WATER TOLERANT.
4. ANY MODIFICATIONS TO THE DEPICTED INFILTRATION BERM SHALL BE ONLY AS APPROVED BY THE TOWNSHIP OR DESIGNATED REPRESENTATIVE.
5. THE TOWNSHIP ENGINEER SHALL BE CONTACTED PRIOR TO INSTALLATION OF THE INFILTRATION BERM TO COORDINATE ANY NECESSARY INSPECTIONS.

REVISIONS	PLAN PREPARATION		BMP - INFILTRATION BERM DETAIL	SCALE AS SHOWN
	DRAWN BY: PSJ	DATE: 08/01/12		
	DESIGNED BY: EMV	CHECKED BY: WFM	FRANKLIN TOWNSHIP SAMPLE STORMWATER MANAGEMENT BMPS FRANKLIN TOWNSHIP, YORK COUNTY, PA	SHEET NO. 3 OF 4

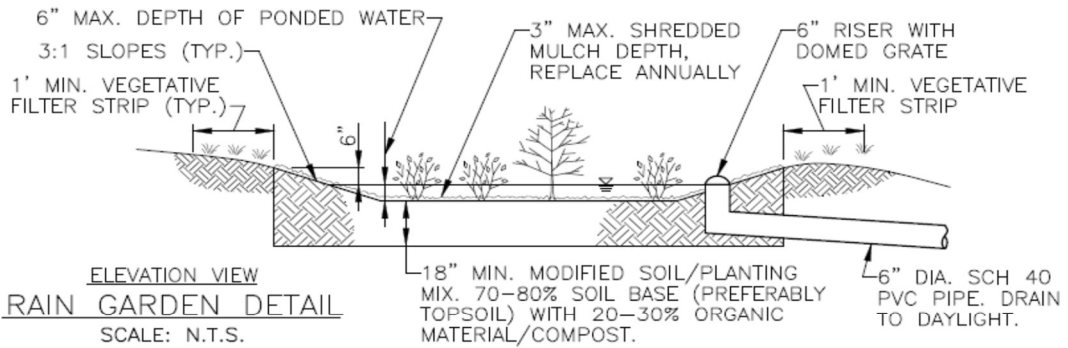
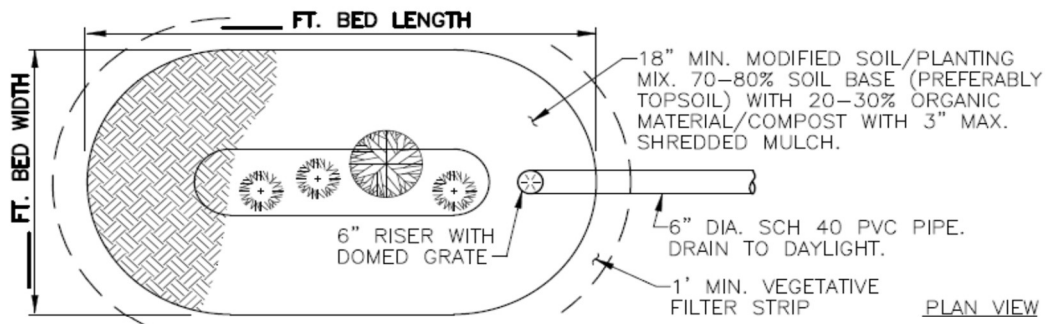

MAINTENANCE AND GENERAL NOTES:

1. RAIN GARDENS REQUIRE INITIAL MAINTENANCE TO STAY HEALTHY. FOR THE FIRST 2 WEEKS, WATER THE GARDEN EVERY OTHER DAY (UNLESS IT RAINS).
2. FOR THE FIRST YEAR, THE RAIN GARDEN REQUIRES WEEDING AND ABOUT AN INCH OF WATER A WEEK.
3. REMULCH RAIN GARDEN ANNUALLY. RAKE REGULARLY TO PREVENT WEED GROWTH.
4. ONCE DURING SPRING AND FALL, DEAD VEGETATION SHOULD BE REMOVED FROM THE RAIN GARDEN AND REPLACEMENT PLANTS SHOULD BE PLANTED.
5. A MIX OF TREES AND SHRUBS IS RECOMMENDED FOR PLANTING. ABOUT ONE TREE FOR EVERY THREE SHRUBS.
6. UNDER DRAINS SHOULD NOT BE USED EXCEPT WHERE IN-SITU SOILS FAIL TO DRAIN SURFACE WATER.
7. ANY MODIFICATIONS TO THE DEPICTED RAIN GARDEN SHALL BE ONLY AS APPROVED BY THE TOWNSHIP OR DESIGNATED REPRESENTATIVE.
8. THE TOWNSHIP ENGINEER SHALL BE CONTACTED PRIOR TO INSTALLATION OF THE RAIN GARDEN TO COORDINATE ANY NECESSARY INSPECTIONS.

REVISIONS	PLAN PREPARATION		BMP - RAIN GARDEN DETAIL	SCALE
	DRAWN BY: PHI	DATE: 08/01/12		AS SHOWN
	DESIGNED BY: EMF	CHECKED BY: WPH	FRANKLIN TOWNSHIP SAMPLE STORMWATER MANAGEMENT BMPS FRANKLIN TOWNSHIP, YORK COUNTY, PA	SHEET NO. 4 OF 4

Guide to Choosing Stormwater BMPs

The Guide to Choosing Stormwater BMPs can be found at the Franklin Township Office or at the Franklin Township Website: www.franklintownship.org

Please see a “SAMPLE” of the
STORMWATER MANAGEMENT/ BMP FACILITIES &
MAINTENANCE AGREEMENT below.

**STORMWATER MANAGEMENT/
BMP FACILITIES & MAINTENANCE
AGREEMENT**

**STORMWATER MANAGEMENT PRACTICES, FACILITIES, AND SYSTEMS
MAINTENANCE AND MONITORING AGREEMENT**

THIS AGREEMENT made and entered into this ____ day of _____ 20 ____,
by and between _____, of
_____, PA, 17 _____, (hereinafter the
“Landowner”), and FRANKLIN TOWNSHIP, York County; Pennsylvania, (hereinafter
“Municipality”);

RECITALS

WHEREAS, the Landowner is the owner of certain real property as recorded by deed in the Office of the Recorder of Deeds of York County, Pennsylvania, in Record Book ____ at Page _____, (hereinafter “Property”).

WHEREAS, the Landowner is proceeding to build and develop the Property, or has become the owner of the property at or after the time that the Property has been developed; and

WHEREAS, the Subdivision Plan, and/or Land Development Plan, and/or Stormwater Management Plan (hereinafter “Plan”) for the Property identified herein, as approved or to be approved by the Municipality, provides for management of stormwater within the confines of the Property through the use of Stormwater Management Facilities and Best Management Practices (BMPs). The Plan is identified as follows: **Stormwater Management Plan for:** _____
_____. The Plan is incorporated in this Agreement by reference; and

WHEREAS, the Municipality and the Landowner agree that the health, safety, and welfare of the residents of the Municipality require that on-site Stormwater Management Facilities and BMPs be maintained on the Property; and

WHEREAS, for the purpose of this agreement, the following definitions shall apply:

Best Management Practices (BMPs) – stormwater structures, facilities, and techniques to maintain or improve the water quality of surface runoff.

Stormwater Management Facilities – any structure, natural or man-made, that (due to its condition, design, or construction) conveys, stores and/or otherwise affects stormwater runoff. Such facilities include, but are not limited to, detention or retention basins, open channels, storm sewers, pipes, and infiltration structures.

WHEREAS, the Municipality requires in Article VII of its Stormwater Management Ordinance that all Stormwater Management Practices, Facilities, Systems, and BMPs be maintained;

NOW, THEREFORE, WITNESSETH, in consideration of the foregoing premises, the mutual covenants contained herein, and the following terms and conditions, the parties hereto agree as follows:

1. Incorporation of Recitals. The Recitals stated above are incorporated herein.
2. Installation/Construction. The Landowner shall construct the Stormwater Management Facilities and the BMPs in accordance with the Plan and specifications identified in the approved Plan.
3. Maintenance by Landowner. The Landowner shall maintain the Stormwater Management Facilities and the BMPs, as shown on the Plan, in good working order in accordance with the specific maintenance requirements noted on the Plan, which Plan is incorporated herein by reference.
4. Entry onto Property for Inspection. The Landowner hereby grants permission to the Municipality, its authorized agents and employees, to enter upon the Property, at reasonable times and upon presentation of proper identification, and inspect the Stormwater Management Facilities, Systems, and BMPs whenever it deems necessary. Whenever possible, the Municipality shall notify the Landowner prior to entering the property.
5. Failure to Maintain is a Nuisance; Abatement by Municipality. In the event the Landowner fails to maintain the Stormwater Management Practices, Facilities, Systems, and BMPs as shown on the Plan in good working order, the parties hereto agree that such failure shall be deemed a nuisance. The Municipality may enter upon the Property and take whatever action it deems necessary to effectuate the maintenance and thereby abate the nuisance. This provision shall not be construed to allow the Municipality to erect any permanent structure on the land of the Landowner. It is expressly understood and agreed that the Municipality is under no obligation to maintain, or repair said facilities, and in no event shall this Agreement be construed to impose any such obligation on the Municipality.
6. Recovery of Expenditures by Municipality; Municipal Lien. In the event the Municipality, pursuant to the Agreement, performs work of any nature, or expends any funds in performance of said work for labor, use of equipment, supplies, materials, and the like, the Landowner shall reimburse the Municipality for all expenses incurred, plus ten per cent (10%) within 10 days of the mailing of an Invoice from the Municipality to the Landowner at his or its last known address. If such payment is not made with the 10-day period, the Municipality may place a municipal lien against the Property pursuant to the procedures contained in the Pennsylvania municipal lien law, 53 P.S. §7101, et seq. as amended.
7. Indemnification by Landowner. The Landowner hereby indemnifies the Municipality and its employees and agents against all damages, casualties, occurrences or claims which might arise or be asserted against said it or them arising from the construction, presence, existence, or maintenance of the Stormwater Management Practices, Facilities, Systems, and BMPs by the Landowner or by the Municipality. In the event that a claim is asserted against the Municipality, its employees or agents, the Municipality shall promptly notify

the Landowner and the Landowner shall defend, at his or its own expense, any suit based on the claim. If any judgment or claims against the Municipality's employees or agents shall be entered, the Landowner shall pay all costs and expenses regarding said judgment or claim.

- 8. Covenant Running with Property. This Agreement shall be covenant running with the Property, and shall be binding on the Landowner's heirs, successors, and assigns.

IN WITNESS WHEREOF, the parties have hereunto either individually or by their authorized officers set their hands and seals the date and year first above written:

Attest:

FRANKLIN TOWNSHIP, YORK COUNTY

Signature

Signature

Print

Print

Franklin Township Secretary

Franklin Township BOS Chairman

[Seal]

COMMONWEALTH OF PENNSYLVANIA
COUNTY OF _____

On this, the _____ day of _____, 20__ before me, the undersigned officer, personally appeared _____, who acknowledged himself/herself to be the _____ of the Franklin Township Board of Supervisors, and that as such and being duly authorized to do so, he/she executed the foregoing instrument for the purpose therein contained.

Notary Public
My commission expires:

Witness:

Landowner:

Signature

Signature, Landowner

Print

Print, Landowner

Signature, Landowner

Print, Landowner

COMMONWEALTH OF PENNSYLVANIA

ss:

COUNTY OF _____

On this, the _____ day of _____, 20____, before me, the undersigned person, personally appeared _____, known to me (or satisfactorily proven) to be the persons whose names are subscribed to the within instrument as Landowners, and acknowledged that they executed same for the purposes therein contained.

IN WITNESS WHEREOF, I have hereunto set my hand and official seal.

Notary Public

My commission expires: _____